

THANK YOU!

You have successfully downloaded a sample woodworking plan from PlansNOW. This sample represents the same level of quality you'll find in more than **200** woodworking projects and technique articles at PlansNOW! See details below.



Tips for Trouble-Free Printing

► **Get the latest version of FREE Adobe® Acrobat® Reader®.** For best results printing our plans, use Adobe Acrobat Reader 5.0 or newer. This is a FREE download.

[Click here](#) or go to www.adobe.com/products/acrobat/readstep2.html

► **Clear memory.** Most printing problems can be avoided by freeing up memory on your computer and printer before printing from Acrobat Reader. Close all other programs that may be running and turn off your printer for at least 15 seconds to flush printer memory.

► **Print in batches.** Our larger project plans will print more successfully if you print a few pages at a time. For example, with a 12 page downloadable plan, select pages 1-6 in the print command window and print these pages only. Then select 7-12 and print.

► **Get advanced printer help.** Visit the Adobe Reader Support web site for detailed instructions in troubleshooting common printer problems.

[Click here](#) or go to www.adobe.com/support/techdocs/150d6.htm

A Plan for Every Project!

Let your imagination go at PlansNOW as you browse **more than 200** woodworking project plans and technique articles—each ready for immediate download to your computer!



Tables-Cabinets

► [Click Here](#)



Home Office

► [Click Here](#)



Shop Storage

► [Click Here](#)



Garden-Patio

► [Click Here](#)



Techniques

► [Click Here](#)

Plans NOW MEMBER

Save 20% on every purchase!

Join our PlansNOW Members list and save 20 percent on every item in the store. You'll also get a FREE downloadable technique article just for signing up!

[Click here](#) or go to www.plansnow.com/join.html

Need Hardware? Woodsmith Project Supplies 1-800-444-7527

For plans that require unique or hard-to-find hardware and accessories, we may have a kit available for purchase. Please contact Woodsmith Project Supplies for more information.

Contact Us. Have a question about PlansNOW? We want to hear from you!

E-mail: ► planman@augusthome.com Phone: ► 1-800-333-5441 (Mon-Fri 8-5 Central time)

DISPLAY CABINET

If you think elegant projects have to be time-consuming and hard to build, take a closer look at this versatile display cabinet that can be built in one weekend!

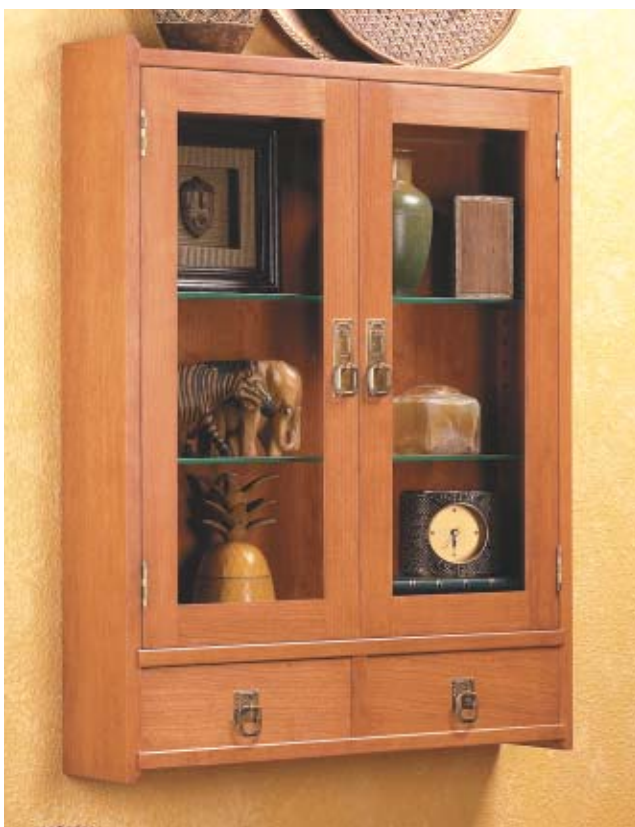

HARDWARE

We ordered our glass from a local glass shop *after* the door frames had been built. The shelf supports, double ball catches, and wood plugs are all fairly common, and if you can't find them locally, you can order them from a variety of online wood-working supply catalogs.

We ordered most of our hardware from *Lee Valley* (www.leevalley.com). The square plate pulls (part no. 01A52.20) went on the drawers. The vertical ring pulls (part no. 01A52.61) were used on the doors. You can also order the 2" x 1³/₈" antique brass hinges (part no. 00E11.07).

Here's a compact wall cabinet that will look great in just about any room of your house, including your shop. It's an easy-to-build project that can be completed in one weekend with a minimum of carpentry tools. For example, in place of the more traditional (and complicated) mortise and tenon joints on the doors, we used simple bridle joints that can be cut entirely on a table saw. We'll show you step by step how to set up your saw for this simple method of joinery.

Also, we've included plenty of design options that will allow you to custom build this project to your own taste. Choose between solid wood or glass for the doors and shelves, and then mix and match different types of hardwood to create a unique overall look to the project. In our shop version of the cabinet, we used a combination of cherry and ash. See photo below.

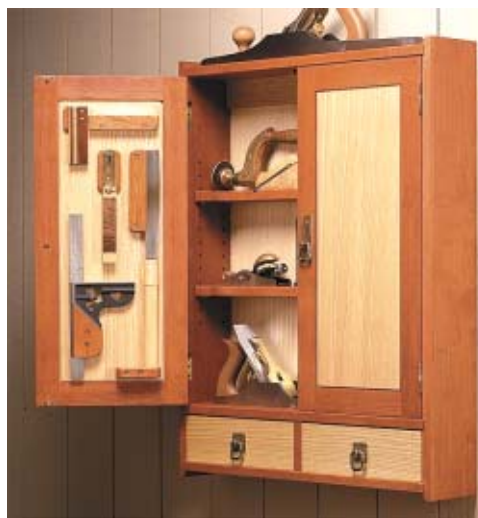

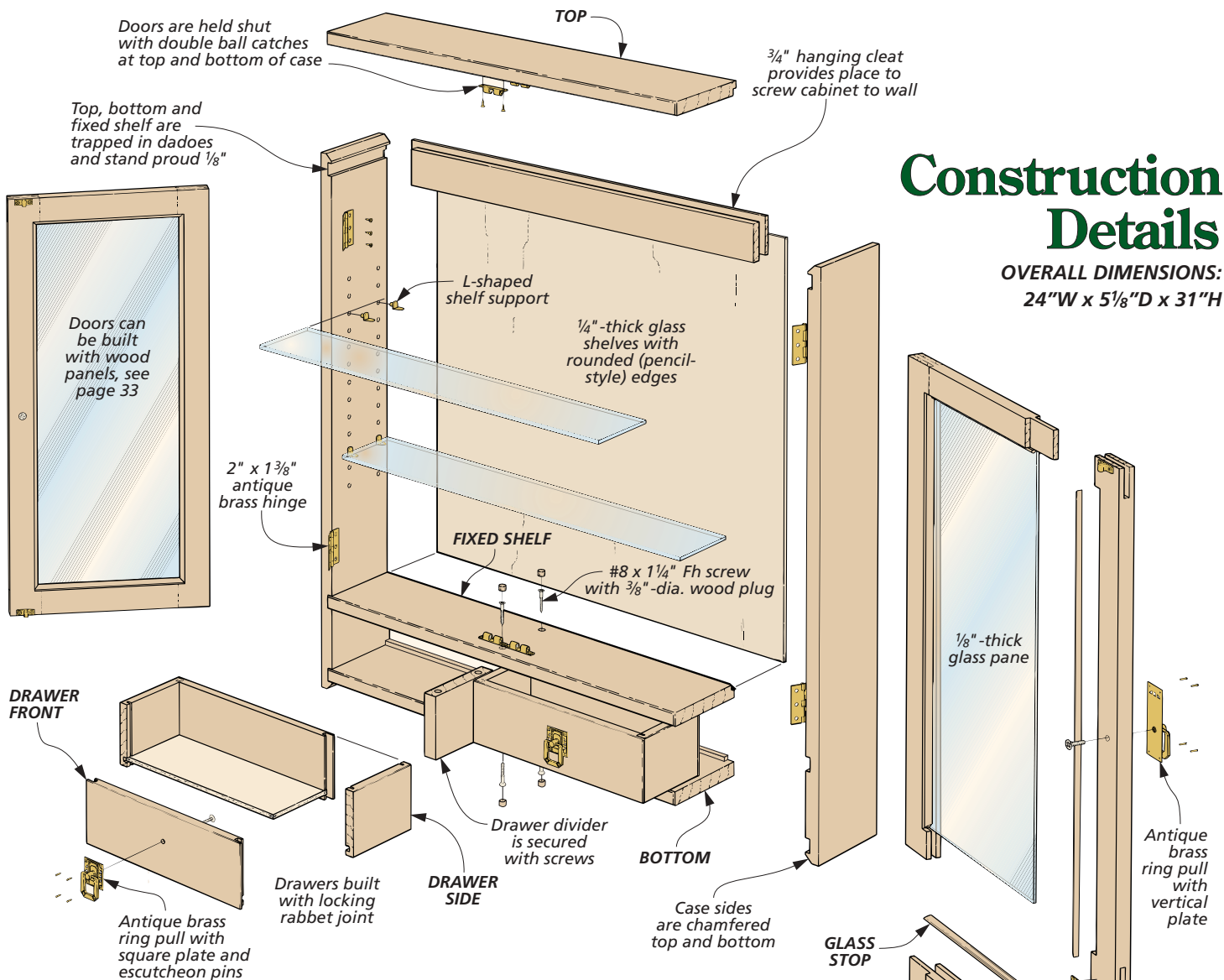

Construction Details

OVERALL DIMENSIONS:
24"W x 5 1/8"D x 31"H

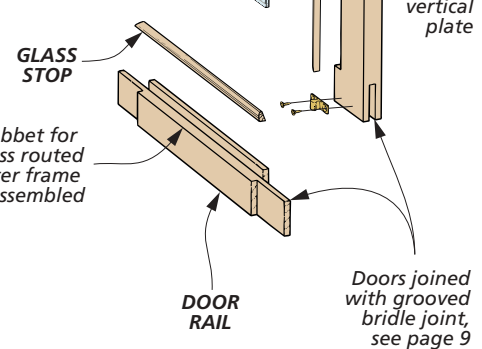

CUTTING DIAGRAM

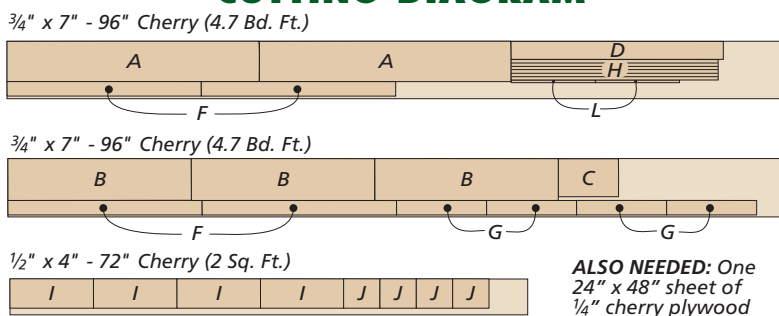

MATERIALS & SUPPLIES

- | | | | | |
|-----------------------------------|----------------------------|---|----------------------------|--|
| A Sides (2) | 3/4 x 5 - 31 | I Drawer Frts./Bks. (4) | 1/2 x 37/16 - 10 13/16 | • (2) 1/8"-Thick Glass (8 5/16" x 21 1/4") |
| B Top/Btm./Fixed Shelf (3) | 3/4 x 5 1/8 - 23 | J Drawer Sides (4) | 1/2 x 37/16 - 4 1/2 | • (1 pkg.) 1/2"-Long Brads |
| C Drawer Divider (1) | 3/4 x 5 - 3 1/2 | K Drawer Btms. (2) | 1/4 ply. - 4 3/16 x 10 1/4 | • (2 pr.) 2" x 1 3/8" Hinges w/Screws |
| D Hanging Cleat (1) | 3/4 x 2 1/2 - 23 1/4 | L Drawer Stops (2) | 1/4 x 1/4 - 10 7/8 | • (2) Ant. Brass Square-Plate Ring Pulls |
| E Back (1) | 1/4 ply. - 23 1/4 x 22 7/8 | • (4) #8 x 1 1/4" Fh Woodscrews | | • (2) Ant. Brass Vertical-Plate Ring Pulls |
| F Door Stiles (4) | 3/4 x 1 3/4 - 24 1/8 | • (4) 3/8"-dia. Wood Plugs | | • (4) Double Ball Catches w/Screws |
| G Door Rails (4) | 3/4 x 1 3/4 - 11 3/16 | • (2) 1/4"-Thick Glass (3 7/8" x 22 1/4") | | |
| H Glass Stop (6) | 1/4 x 1/4 - 22 rgh. | • (8) L-Shaped Shelf Supports | | |
- *Note: The supplies listed above are for the cabinet design with the glass-paneled doors.



▲ Though this case has some unique features, it's built with basic dado construction. For more on cutting dados and grooves, see our **Woodworking Basics** series at PlansNOW.com

Case

The basic case of this display cabinet is quite simple — just a pair of sides that trap a top, bottom and a single, fixed shelf, as you can see in Fig. 1. Later, you'll add a vertical divider to create the drawer openings, a cleat for hanging the cabinet, and a plywood back. But for now, you can focus on the basic case pieces.

SIDES, TOP, BOTTOM & SHELF.

The first thing to do is cut the sides (A) and the top, bottom and shelf (B) to size from $\frac{3}{4}$ "-thick stock. (I chose to build this cabinet in cherry, but it would also look great in other woods like oak or maple.) Before you rip the top, bottom and shelf to width, note that they're slightly wider than the sides so they will stand $\frac{1}{8}$ " proud, as shown in the photo at left and Fig. 1b.

The sides require the most work, so I started with them. First, I cut a chamfer on both ends, as shown in Fig. 2. This is a fairly deep chamfer, so instead of cutting it in multiple passes with a router bit, I cut it on the table saw using an auxiliary miter gauge fence to support the piece.

You can leave the auxiliary fence in place while you cut the dados to hold the top, bottom, and shelf, as shown in Figs. 1a and 3. And to make sure the dados line up across from each other, you'll want to either add a stop to the end of the auxiliary fence or use the rip fence as a stop, as I did in Fig. 3. (You can do this because the cuts don't go all the way through, so there are no waste pieces to kick back at you.)

The last thing to do on the side pieces is drill the series of $\frac{3}{8}$ "-deep holes for the L-shaped shelf supports that will hold the glass shelves.

Before the case can be assembled, you'll need to do a little work on the top, bottom and shelf. First, the front edge of each needs a $\frac{1}{16}$ " chamfer, as indicated in Fig. 1b. Then in the shelf and bottom pieces, you'll want to drill the two counterbored shank holes that will hold the drawer divider.

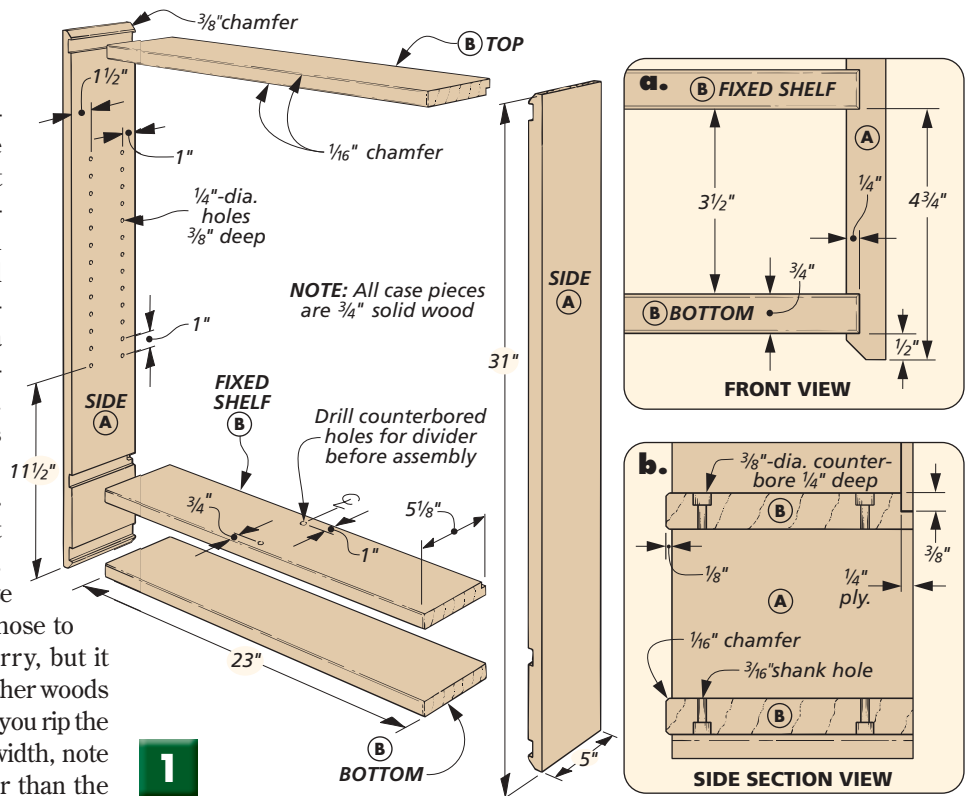

1

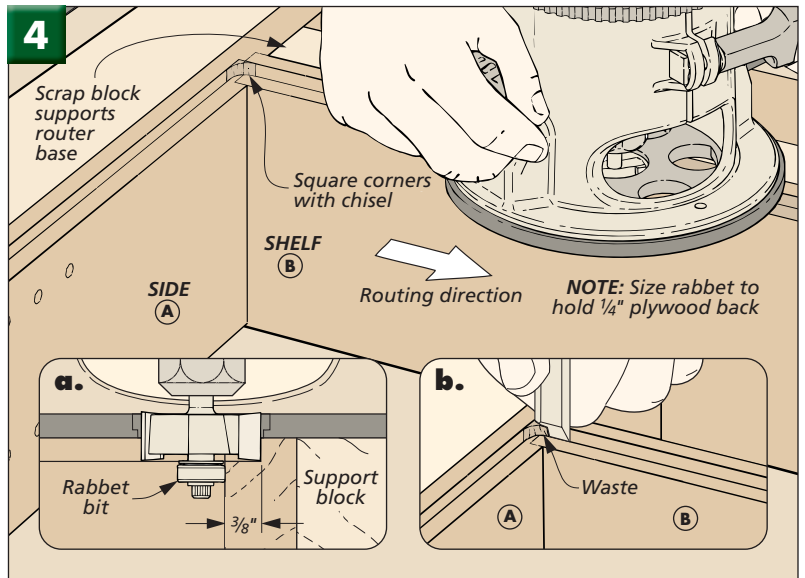
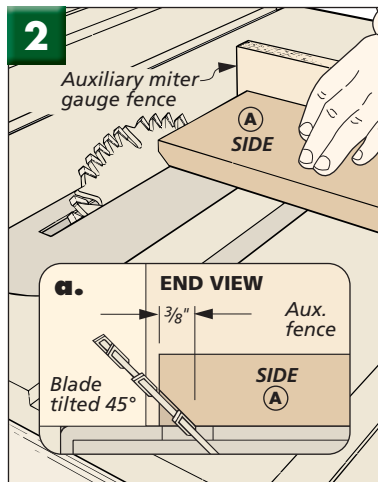

(It would be a bit awkward to do this after assembly.)

Gluing this case together isn't hard. Just remember the top, bottom and shelf stand proud in front of the case and are flush in back.

After the glue on the case is dry, the next thing to do is rout the rabbet for the 1/4" plywood back panel. As you can see in Figs. 4 and 4a, I did this with a hand-held router, using scrap blocks to help support the router base so it wouldn't tip. Then I came back and cleaned up the corners with a chisel (Fig. 4b).

DRAWER DIVIDER. Before you cut the back to size, there are two other pieces to make. First I cut a *drawer divider* (C) to fit between the shelf and bottom, as shown in Fig. 5. But note that the front of the divider sets back 1/8", just like the sides (Fig. 5a).

After screwing the divider in place (Fig. 5a), the screws can be covered with 3/8"-dia. wood plugs. (I'd recommend you use face grain plugs here so they'll be less noticeable.)

HANGING CLEAT. The next piece I added was a *hanging cleat* (D), as you can see in Fig. 5. This way, when hanging the cabinet on the wall later, I had a 3/4"-thick solid-wood piece to screw through, instead of the 1/4" plywood back.

Making the cleat is a two-step process. It's cut to fit between the rabbets for the back, but to get it to fit flush with the back, you'll need to cut a rabbet around three edges of its front face, as shown in Figs. 5b and 6. The second step is just cutting another rabbet — this time, to match

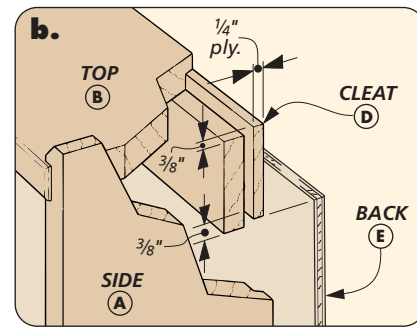
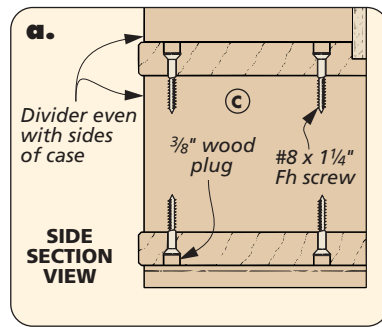
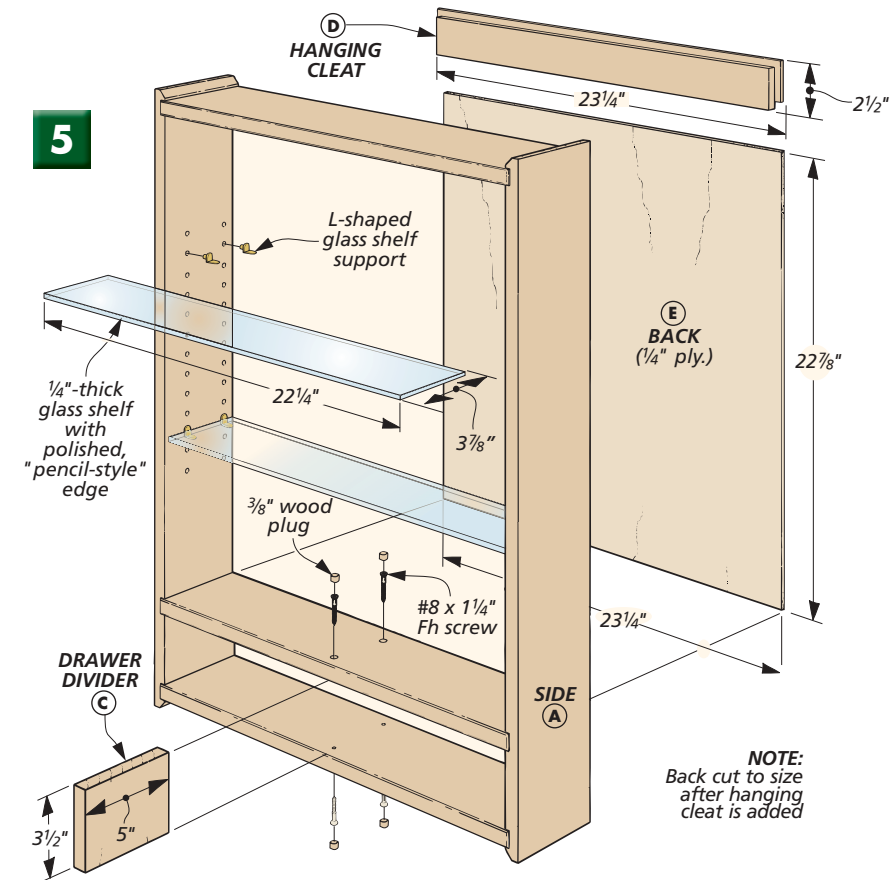

the rabbets in the case for the back, as you can see in Fig. 7.

BACK. When the cleat has been glued in place, you can cut the plywood back (E) to size and glue it into the rabbet (Fig. 5b).

GLASS SHELVES. You really don't need to order the glass for the shelves until you order the glass for the doors later. But I'll just mention here that I used 1/4"-thick glass that had polished, "pencil-style" edges.

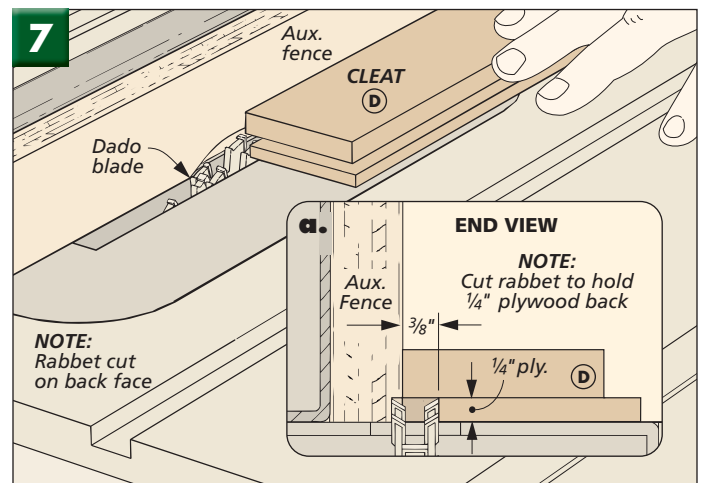
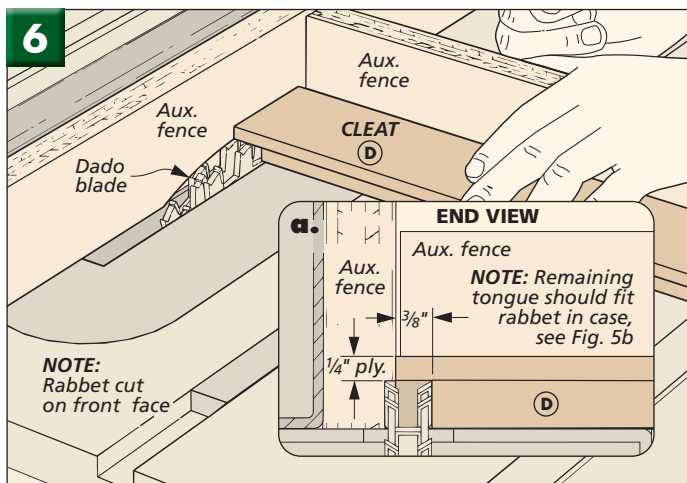

Doors

At this point, the case is ready for the doors, and whether you build them with glass or wood panels, the procedure starts out the same. The door frames are built with a grooved bridge joint. But more on that in a minute.

CUT TO SIZE. Before cutting the door stiles (F) and rails (G) to size (Fig. 8), measure your case so the door pieces can be cut to fit its opening. The stiles are sized so there will be a $\frac{1}{16}$ " gap at the top and bottom of each door. The rails are a bit more work, but at least with a bridge joint, they're the full width of the door. Here, I allowed for a $\frac{1}{16}$ " gap on the sides of the case but no gap between the two doors. (Later, you'll trim the edges where the doors meet, as in Fig. 8b.)

BRIDLE JOINT. With the pieces cut to size, you're ready to cut the bridge joint, see Fig. 8a. I came up with a quick jig (shown in the margin photo) that eliminates one of the setups. And I've described the jig (and how to cut the bridge joint) on page 8 and 9.

DOOR PANELS. If you're building the doors with wood panels, you'll need to make them *before* you glue up the frame, see bottom of page 6. For glass doors, you can glue up the frames now. (Later, you'll rout a rabbet for the glass to fit into.)

HINGE MORTISES. With the door frames glued up, I cut the mortises for the hinges next, as shown in Fig. 9. This can be done at the table saw, and I sized the mortises to match the full depth of the hinge barrel, minus $\frac{1}{16}$ "

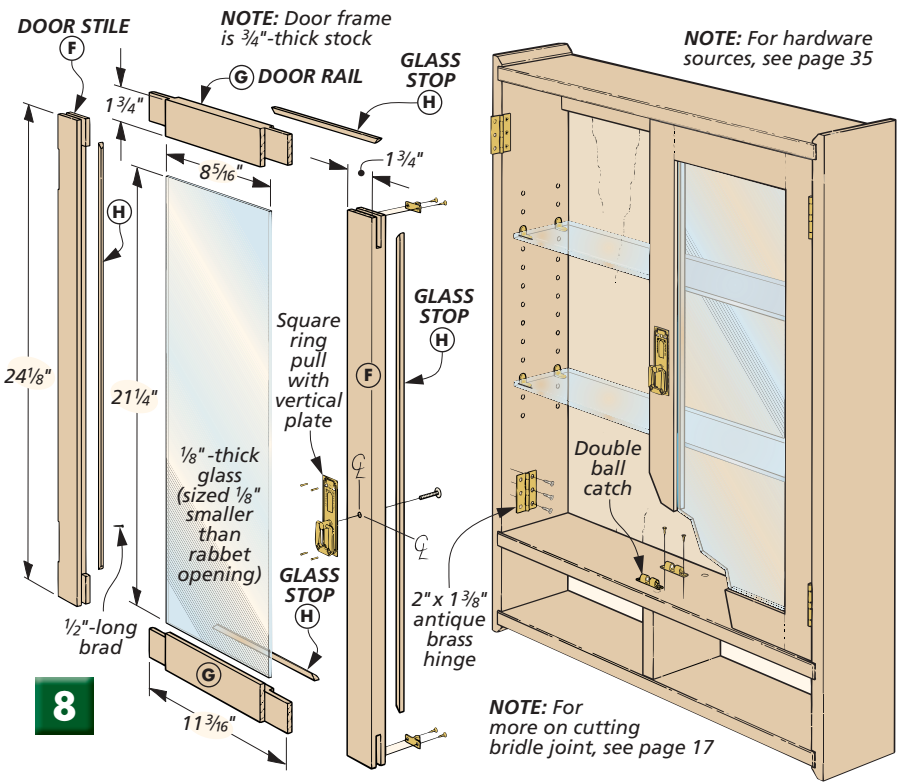

8



▲ This jig lets you cut the open mortises without having to adjust the fence. For details, go to page 8.

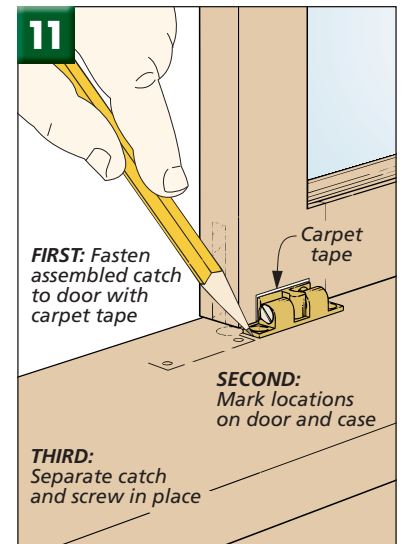
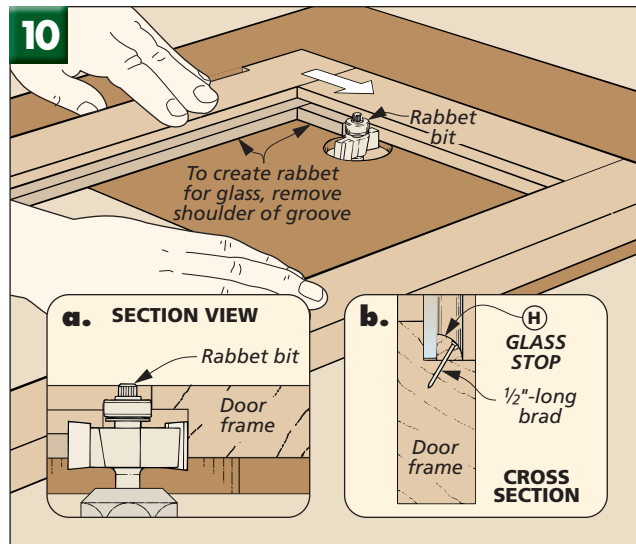
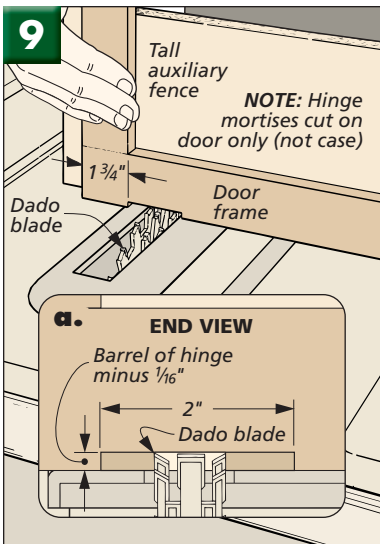
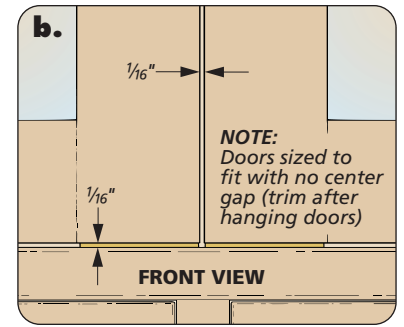
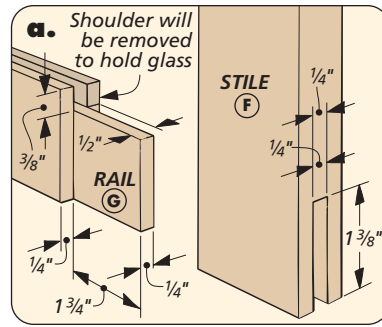

for the gap. (The hinges are simply screwed to the inside of the case.)

Now you can rout the back edges of the doors to hold the glass, as in Fig. 10. I used $\frac{1}{4}$ " glass stop (H) to mount the glass (Fig. 10b). And on page 8, there's a "miter box" I used to

cut the stops to length. (But you don't want to add the glass until the finish has been applied to the project.)

HANG DOORS. At this point, the doors can be hung in the case. Then you can trim their inside edges to create the $\frac{1}{16}$ " gap (Fig. 8a) and add the pulls

and catches. The double ball catches I used can't be adjusted after they're screwed in place, so for an accurate installation, I positioned them with carpet tape, as described in Fig. 11.

DRAWERS

All that's left now is to build the two small drawers, as shown in Fig. 12. I sized the $\frac{1}{2}$ "-thick *fronts* (I) and *backs* (I) so the drawers would be $\frac{1}{16}$ " smaller than the openings in height and width. And the *sides* (J) are sized so the drawers would stop $\frac{1}{4}$ " short of the back of the case.

LOCKING RABBET. To create a strong drawer without a lot of fuss, I decided to use a locking rabbet joint (Fig. 12a). It looks more complicated than it really is. In fact it can be cut in three quick steps on the table saw.

First, a centered groove is cut on the ends of the front and back pieces, as shown in Fig. 13. The key here is that the height of the blade matches the thickness of the drawer sides.

Next, I trimmed the inside face of the front and back pieces to create a

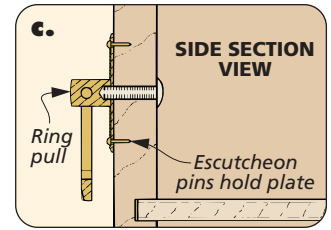
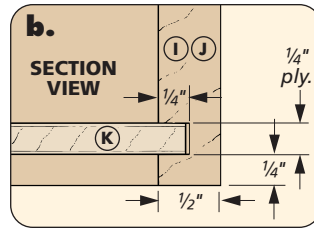
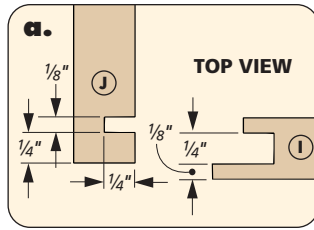
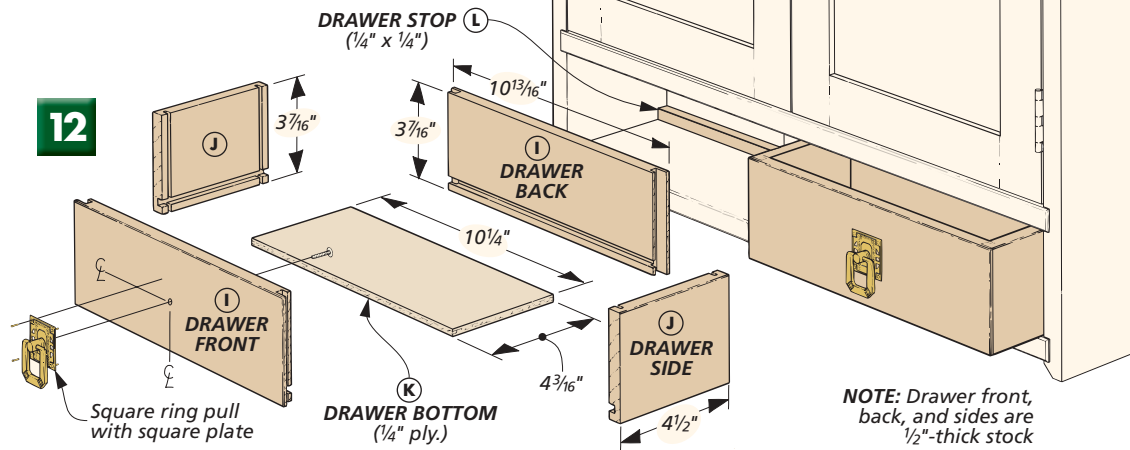

$\frac{1}{4}$ "-long tongue, as shown in Fig. 14.

The last step is to cut dados on the sides (Fig. 15). Just position the dados to line up with the tongues cut in the fronts and backs (Fig. 12a).

BOTTOM. Now each drawer piece is ready for a groove that will hold the $\frac{1}{4}$ " plywood *bottom* (K), as in Fig.

12b. Then when the bottoms are cut to size, you can glue the drawers together and add the pulls (Fig. 12c).

STOP. All that's left now is to cut two *stops* (L) for the back of the case. They're sized so the drawer will end up flush with the *sides* of the case. (Mine were $\frac{1}{4}$ " wide.) **W**

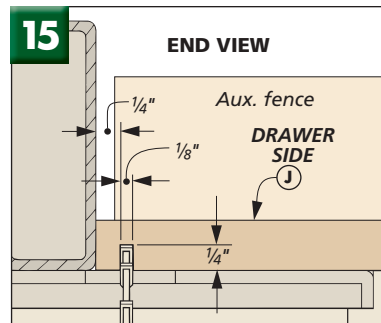
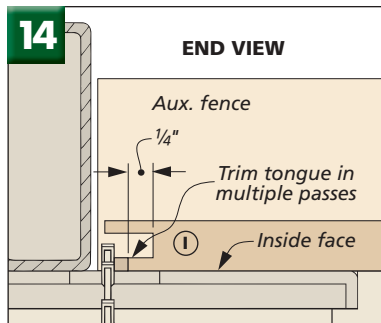
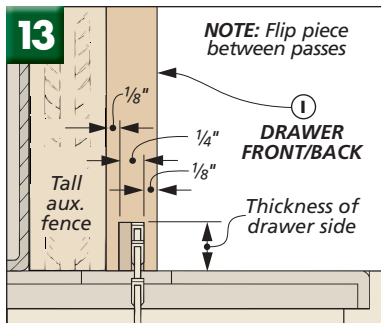

WOOD PANEL DOOR



For an elegant *storage* cabinet, you can build the doors with wood panels instead of glass. (You can also add wood shelves inside.)

Each panel is sized so it'll fit in the grooves when the door is glued together. (Be sure to allow a small gap on each side so the panel can expand and contract.) To create the tongue, all you need to do is rabbet each face, see drawing. And when assembling the frame and panel, remember *not* to glue the panel into the frame.

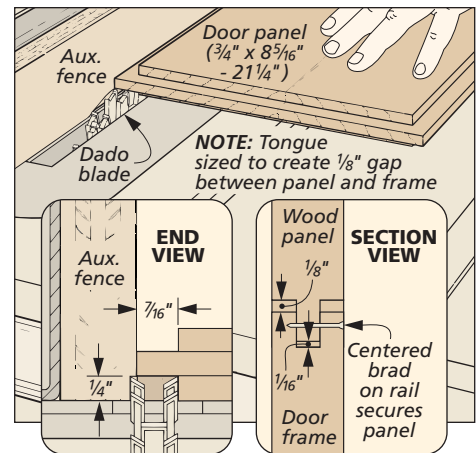

STORING HAND TOOLS

The display cabinet is sized just right to make a great tool cabinet for those special hand tools you want to keep accessible — and protected. Of course, whether you build a “fine” cabinet (with cherry and ash, like the one here) or choose less expensive wood is up to you. Either way, there are a few things to keep in mind as you’re adapting this cabinet for tool storage.

WOOD PANELS. To make the best use of the space inside the cabinet, I decided to build the doors with solid-wood panels instead of glass. This way, I could store tools on the doors, as well as

on the shelves (and back). But to do this, you have to make sure there will be enough clearance inside the cabinet. This means cutting shallow recesses in the front edges of the shelves or cutting narrower shelves (and changing the locations of the holes for the shelf pins), as in the drawing above.

TOOL HOLDERS. It’s not hard to design and build your own custom tool holders. The goal is to get them to hang securely so they don’t fall (or swing) whenever the door is opened. At the same time, you want them as easy to lift off and set back on as possible. Plus, if there are sharp edges, like the teeth on a hand saw or the point of an awl, you want to be sure that other tools (and your hands) are protected.

There are a number of ways to accomplish this, as you can see in the photos below. Simple kerfs are great for holding the blades of saws, squares, and rulers. For awls, chisels, and files, I drill counterbored holes that trap the handles and then cut slots for easy access. And for marking gauges and block planes, you can make a small shelf platform. Here, you’ll want to add small cleats

to the edges so the tools won’t slide off as the door is opened and closed.

When you’re making these small holders, it’s best to do as much work as you can with the pieces oversized. This keeps your hands as far away from the blade as possible.

The photos below show just a few of the tool holder ideas we came up with for our cabinet. To see some more ideas, go to the Online Extras section on our web site: www.Woodsmith.com. **W**

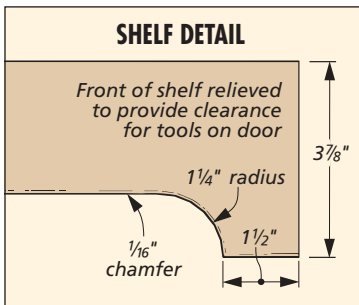

ORGANIZING TOOLS. In order to get the most use out of the doors, I decided to spend a little time planning which tools would work best where. To do this, I simply laid the cab-



Scratch awl. An open hole traps the handle of this awl. And to protect your hands (and other tools), the point sits in a base.



Hand saw. A kerf can be used to protect the teeth of a hand saw. To support the saw, I added a simple base, see main photo.



Marking gauge. For this marking gauge, a notched block supports the head, and a small lip keeps the tool from sliding off.



Combination square. A small angled block with a shallow kerf is all you need to capture a combination square.

SHOP NOTES



Mitering Glass Stop

When mitering glass stop, the trick is to work with the fragile $\frac{1}{4}'' \times \frac{1}{4}''$ strips safely. So when it was time to cut the stop for the glass doors on the display cabinet, I decided to leave my table saw turned off and miter the pieces with a hand saw, as shown in the photo at right.

MITER BOX JIG. To do this accurately, I made a quick

miter "box" sized for small strips. As you can see in Fig. 1, this is just a piece with a groove cut in it to hold the glass stop blanks. (The stops shouldn't fit the groove tight, or you'll have a hard time adjusting them from side-to-side.) This miter "box" is glued to a cleat so the T-shaped jig can be clamped into a bench vise.

Of course the critical part of making this jig is accurately cutting the kerfs that guide the hand saw. And to do this, I used my combination square, as shown in Fig. 2. Then to hold the small

strips in place, I gripped them with my fingers. But I found that the saw tended to bind in the kerf. So for a quick solution, I rubbed a little wax on the blade, as in the margin photo at left. **W**

▲ To allow my hand saw to slide smoothly in this miter "box," I applied a little wax to each face.

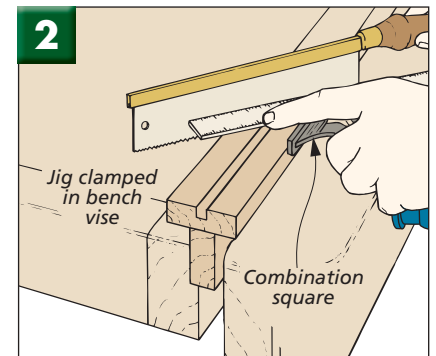
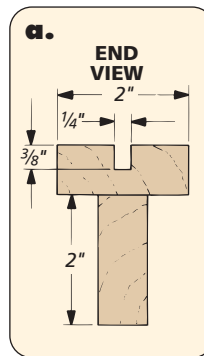
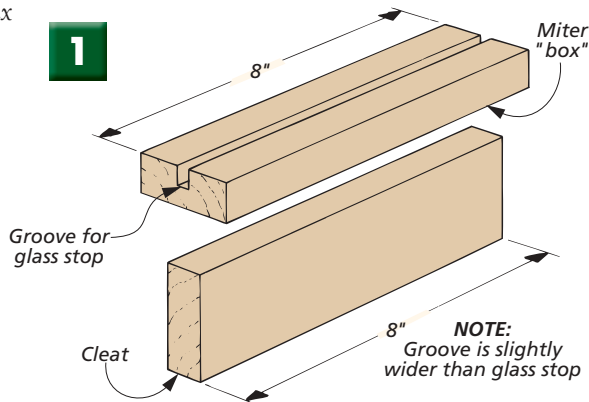

▲ This push block lets you cut the mortises without having to reset the fence.

Make a Bridle Jig

I needed a simple push block to support the stiles while the mortises were being cut. Plus, I wanted to use the same fence setting as the groove setup so the mortises would align with the grooves. This push block does the trick. Its body matches the stile's thickness ($\frac{3}{4}''$), and the hardboard arm extends past the front of the body to prevent the piece from tipping as it's pushed across the blade.

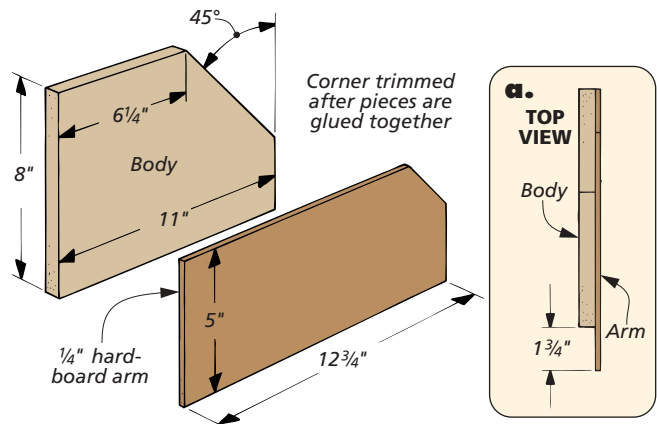

Bridle Joint

This display cabinet has door frames with grooves on their inside edges to hold a panel. As you can see in the upper photo at right, a bridle joint (or open mortise and tenon) is a good choice for this type of frame. It's plenty strong to hold a glass panel, and the whole process can be done on the table saw. All you need is the simple bridle jig (see page 8). Be sure to build the jig *before* you get started on the joint.

GROOVE. The first step to building the frames is to make a centered groove on each piece, as in Fig. 1. Technically, this isn't part of the joint, but you'll use this same fence setting to cut the mortise next.

To cut the groove, I made a couple passes over a regular blade. Flipping the pieces between passes automatically centers the groove. And you'll want to sneak up on the position of the fence until the grooves are $\frac{1}{4}$ " wide.

MORTISE. Now you can cut the mortises in the stile pieces, as in Fig. 2. You don't want to change the fence for this step. The mortises should align with

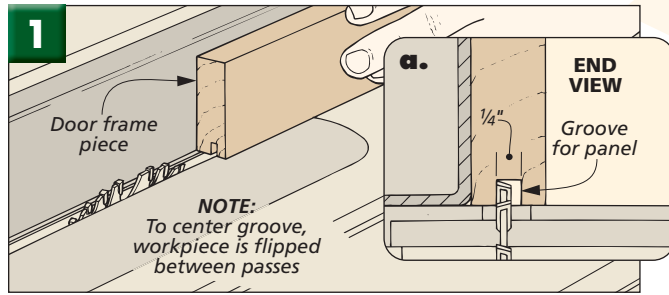

▲ Unlike a traditional mortise and tenon, a bridle joint can be cut completely on the table saw.

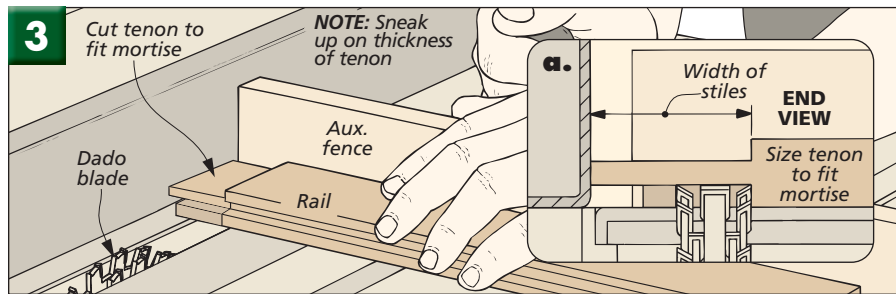
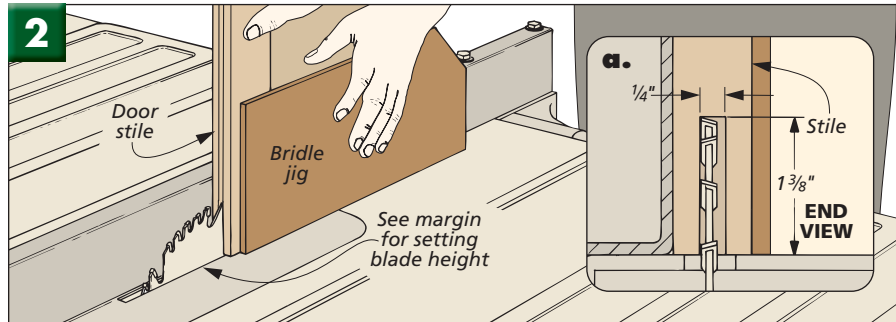

▲ To set the blade at the right height for the mortise of the bridle joint, raise it until it aligns with the groove in one of the rail pieces.

the grooves. But you will need to raise the blade to set the depth of the mortises, as indicated in the lower margin photo. This way, the mortise's depth will automatically match the width of the tenon.

Cutting the mortises is

the same two-step process you used when cutting the grooves. Only this time, the workpieces will be cut standing on end (supported by the jig).

TENON. All that's left now is to cut a tenon to fit the mortise. As you can see in

Fig. 3, I laid the rails down for this step, making multiple passes over a dado blade. Set the fence so the tenon matches the width of the stiles. Then sneak up on the height of the blade until the tenon fits snug in the mortise. **W**