

# Panalign Strips

Cabinetmakers have searched for a material to place inside the stile to allow for expansion and to keep the panel centered. Carpet foam eventually loses elasticity and ceases to work. The rubber in Panalign Strips is specially designed to spring back indefinitely, keeping panels centered while allowing them to expand and contract with changing humidity. They are also the solution for a panel that has been sanded so much that it is loose and rattles: inserting the strips keeps the panel snug but not fixed. The rectangular shape makes the strips easy to handle. Typical doors take between 4-8 strips each.

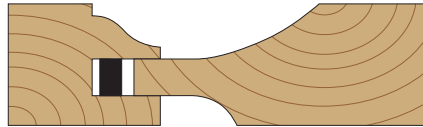

Description	Q.ty	Order No.	List Price \$
Panalign strips	200	PNL - 001	<b>5.50</b>
Panalign strips	500	PNL - 002	<b>12.50</b>
Panalign strips	1.000	PNL - 003	<b>22.50</b>

## Arched Raised Panels Made Easy *video*

Cabinetmaker and teacher Marc Sommerfeld demonstrates the use of the new Sommerfeld Cabinetmaking Set of router bits made by CMT. He shares his techniques and time-saving tips while making straight and arched raised panel doors on his newly-designed router table. This instructional video shows how to make straight and arched raised panels that rival those made by expensive machinery.

Every step is thoroughly covered, including:

- figuring the dimensions of the stiles, rails, and panels
- squaring up and cutting all five pieces on the table saw
- performing the cope cut, pattern cut, and panel cut
- machining curves with templates
- flush trimming the curved panels and rails
- assembling and glueing up the door
- placing Panalign Strips to keep panels centered
- detailing the outside edge of the door
- raising the drawer front



Further instruction emphasizes safety by demonstrating a half-fence for the free-hand operation and by using two different-sized bearings on the panel cutter to make two shallow passes. Approximate time: 40 minutes

Description	Order No.	List Price \$
Video	VID - 001	<b>24.95</b>

# Templates

Some woodworkers have avoided making arched raised panel doors for two reasons: the difficulty of making arched cuts and the expense of hold-down jigs. This system solves both problems by eliminating the need for high-cost hold-down jigs and by providing step-by-step instructions with the templates. A companion video is also available.

The twenty-piece template package includes ten sizes for the panels and the ten corresponding templates for the matching arched rails. Each template is individually stamped with its size which indicates overall door width; any door size between 9-1/2" and 22" can be made. All templates are made of rugged HDPE plastic for years of repeated use. The five styles offered are pictured below.

new  
item

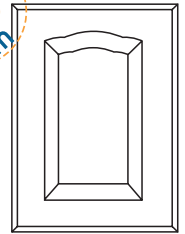
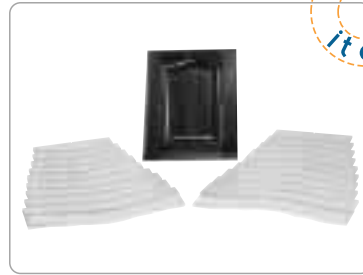

**Sommerset**

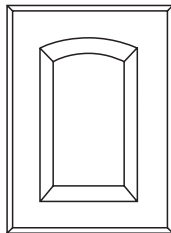
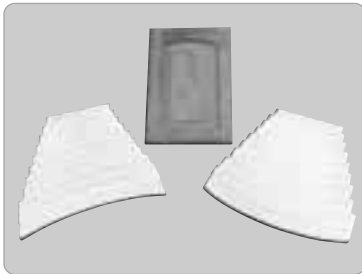

**Roman**

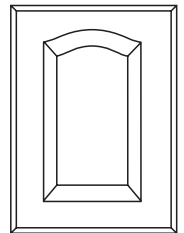
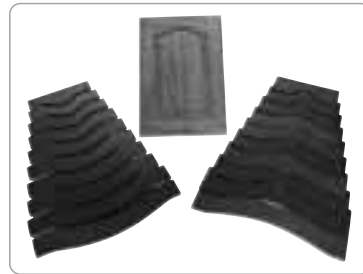

**Cathedral**

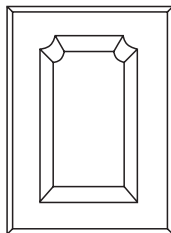
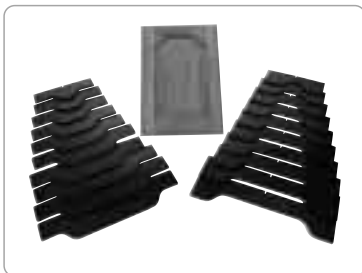

**Classic Country**

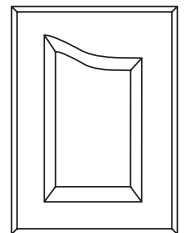
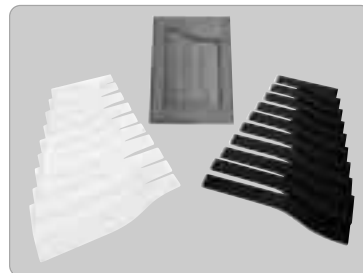

**French Provincial**

Description	Color	Order No.	List Price \$
French Provincial	black/white	TMP - 001	<b>133.50</b>
Classic Country	black	TMP - 002	<b>133.50</b>
Cathedral	blue	TMP - 003	<b>133.50</b>
Roman	white	TMP - 004	<b>133.50</b>
Sommerset	yellow	TMP - 005	<b>133.50</b>

# Arched Raised Panel Doors

## Made Easy *by Marc Sommerfeld*



### STEP 1. MAKING A SAMPLE DOOR

- A) This sample door size is 12" wide by 20" long. Preferably 13/16"
- B) The door thickness should be 3/4" - 7/8"

### STEP 2. DETERMINING THE SIZES OF EACH PART OF THE DOOR

- A) Always use a 1/2" overlay on all sides of the door.
  - B) If the door opening is 11" wide by 19" high then the door size is 12" x 20".
- IMPORTANT: Use 2-7/16" wide stiles so the templates will work properly.

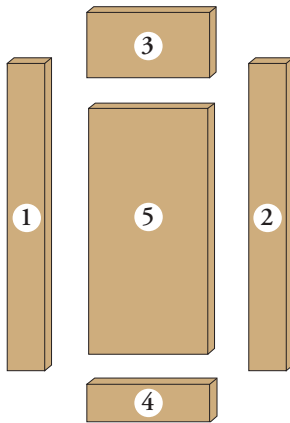

1. LEFT STILE  
3/4" x 2-7/16" x 20"
2. RIGHT STILE  
3/4" x 2-7/16" x 20"
3. TOP ARCHED RAIL  
3/4" x 4-1/4" x 8"
4. BOTTOM RAIL  
3/4" x 2-7/16" x 8"
5. RAISED PANEL  
3/4" x 7-3/4" x 16"

#### 1-2. LEFT AND RIGHT STILES

- a) Always cut stiles 2-7/16" wide.
- b) Length of stiles is same as door length.

#### 3. TOP ARCHED RAIL

- a) Cut 4-1/4" wide. Templates are 4" wide.
- b) Length of rail is found by subtracting 4" from the total door width. (Overall door width is 12" minus 4" = 8" length of rail) NOTE: This following procedure can only be used when using 2-7/16" wide stiles. Subtract 4" from the total door width instead of 4-7/8" since 7/16" in each stile will be taken up in the pattern cut.

#### 4. BOTTOM RAIL

- a) Always cut 2-7/16" wide.
- b) Length of rail is again found by subtracting 4" from the total door width. (Overall door width is 12" minus 4" = 8" for bottom rail lengths)

#### 5. RAISED PANEL

- a) Width is always 1/4" less than rail length. (1/8" space should be left on each side for expansion of panel)
- b) Rail length is 8" minus 1/4" = 7-3/4" width of raised panel.
- c) Length of raised panel is found by taking the overall door length and again subtracting 4". (Overall door length is 20" minus 4" = 16" length of panel)

SUBTRACT 4" FROM THE OVERALL LENGTH OF THE DOOR. SUBTRACT 4" INSTEAD OF 4-7/8" SINCE THE PATTERN CUT TAKES UP 7/16" ON EACH RAIL.

At this time all 5 pieces of the door should be cut to the correct size.

**ALWAYS USE SAFETY PUSH BLOCKS AND EYE AND EAR PROTECTION WHEN OPERATING A ROUTER.  
SEE "SUGGESTIONS FOR SAFE ROUTING" ON PAGE 5.**

### STEP 3. CUTTING THE COPE CUTS ON EACH END OF THE 2 RAILS

- A) Cope cutter is the cutter with the bearing in the middle
- B) Set the cope cutter to the correct height in the router.
  - 1) The correct height is when, after the cut is made, the reveal on the front side should be 1/8" minimum (Illustration 1)
  - 2) Spaces A and B shown should be equal. If one is to be bigger, make B thicker for strength of panel.
- C) Set fence even with bearing.
- D) Use wooden push-block to prevent tearout at end of cope cut.
- E) Run stock through with good side down at 14,000-16,000 RPMs.

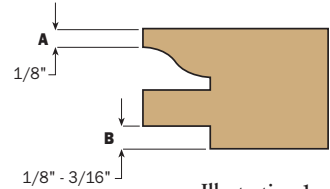

Illustration 1

### STEP 4. USING RAIL TEMPLATE TO FLUSH TRIM TOP RAIL TO CORRECT SHAPE

- A) Locate center of top rail with pencil on the back side.
- B) Pick out the correct template.

**NOTE:** THE SIZE ON THE TEMPLATE IS FOR THE OVERALL DOOR WIDTH. FOR THE TEMPLATES TO WORK PROPERLY STILES MUST BE MADE 2-7/16" WIDE. IF STILES ARE MADE IN DIFFERENT WIDTHS, ADJUSTMENTS IN PICKING OUT TEMPLATES MUST BE MADE.

- C) Line up template on back side of rail centering the notch of template with center line of rail. Now nail through the template into the 2 copes that were just cut (Illustration 2).

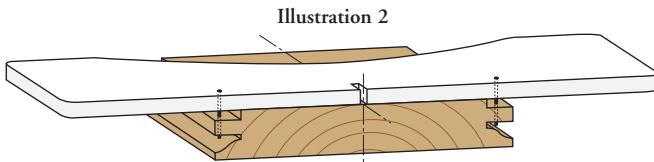

Illustration 2

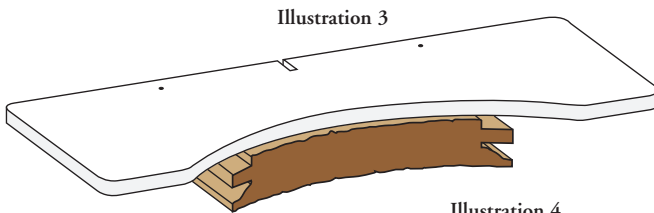

Illustration 3

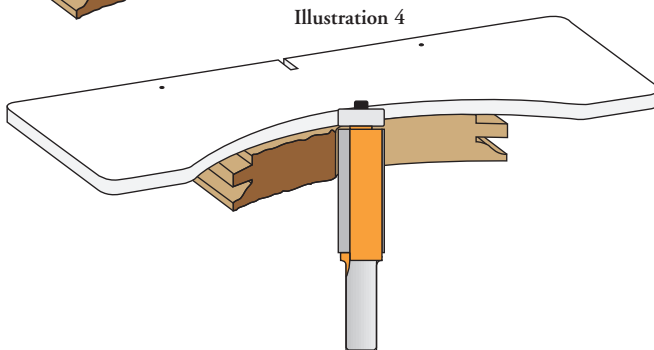

Illustration 4

- D) Rough cut with jig or band saw within 1/8" or 1/4" of template (Illustration 3).

- E) Put flush trimming bit into router and set so bearing is flush with template (Illustration 4).
- F) Run router at 20,000-22,000 RPMs and flush trim top crown rail with good side down.

**NOTE:** WHEN STARTING CUT, ALWAYS REMEMBER TO MAKE CONTACT WITH BEARING TO A PLACE ON THE TEMPLATE WHERE THERE IS NO WOOD TO PREVENT KICKBACK.

- G) Slow down at end of cut to prevent tearout. Leave template attached to rail for now.

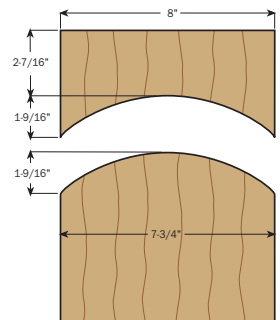

# Arched Raised Panel Doors

## Made Easy *by Marc Sommerfeld*

### STEP 5. USING PANEL TEMPLATE TO FLUSH TRIM THE RAISED PANEL TO SHAPE

- A) Locate center of raised panel on front side.
- B) Pick out correct template (same size as rail template).
- C) Line up center notch of template with center line of panel and make sure it is also square (Illustration 5).
- D) Nail template to panel about 1/2" in from each side (Illustration 5).

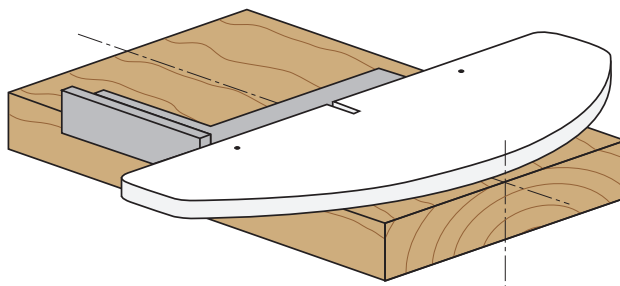

Illustration 5

**NOTE:** DRIVE NAILS IN ABOUT 1/4"-3/8".

THE NAIL HOLES WILL BE MACHINED OUT WHEN RAISED PANEL CUT IS MADE.

- E) Rough cut stock to within 1/8" - 1/4" of template.
- F) Flush trim raised panel in the same manner as you did the top rail with the template on top (Back to illustration 4).

**NOTE:** AGAIN MAKE SURE BEARING COMES IN CONTACT WITH TEMPLATE FIRST AND THEN GUIDE INTO THE WOOD.

- G) Pull nails out after flush trimmed.

### STEP 6. CUTTING FREEHAND PATTERN CUT ON TOP ARCHED RAIL

- A) Pattern cutter is the cutter with the bearing on top.
- B) Insert pattern cutting bit to correct height to match cope cut. This can be done by making a few practice cuts in scrap wood.
- C) Run router at 14,000-16,000 RPMs.
- D) Start cut with bearing making contact with template only and ease into cut. No fence is used. (Illustration 6).
- E) Slow down at end of cut to prevent any chipout.
- F) Remove template from top arched rail.

### STEP 7. CUTTING THE STRAIGHT BOTTOM RAIL AND 2 STILES

- A) Insert fence and line up fence with bearing on the same pattern cutter.
- B) Run router 14,000-16,000 RPMs
- C) Use push-block and push bottom rail through with good side down.

Illustration 6

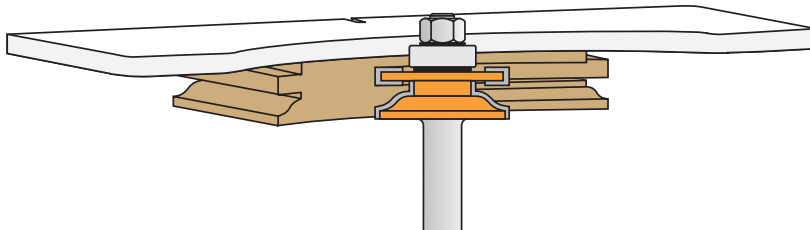

## STEP 8. MAKING RAISED PANEL CUT

A) Insert panel cutter to correct height.

**NOTE:** IT MAY TAKE A COUPLE OF PRACTICE CUTS IN SCRAP WOOD BEFORE GETTING THE PANEL FLUSH WITH PATTERN CUT.

B) Set fence so it is even with bearing on panel cutter.

C) Run router slow 10,000 RPMs. ALWAYS USE PUSH BLOCKS FOR SAFETY.

D) Make first cut across the grain with good side face down.

E) Cut with the grain on left side.

F) Remove fence and use a half-fence. (Illustration 7)

G) Start by re-doing left side and come around and cut the curved top of the panel freehand.

H) Install full fence and complete right side.

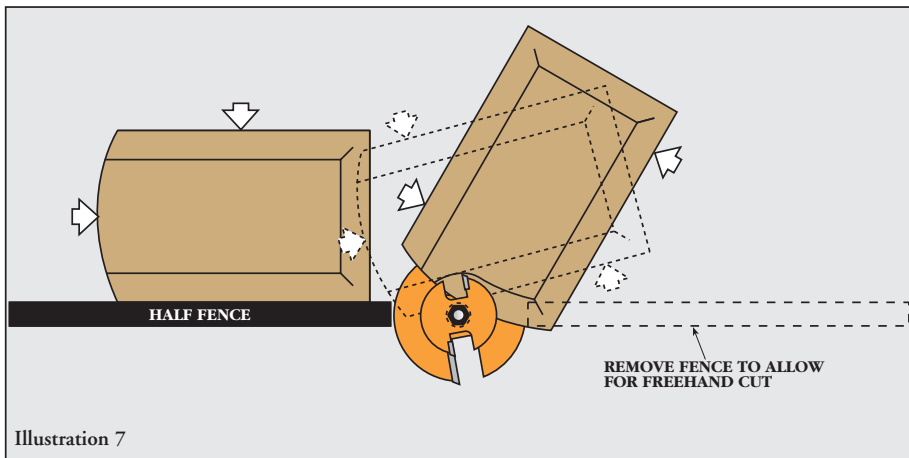

## STEP 9. FINISHING

A) Sand all pieces where needed, insert Panelign Strips (see catalogue page 12), and glue up. Do not glue raised panel itself, only cope cuts and where they meet the pattern cuts.

B) After the door is sanded, use the door edger bit for a professional looking edge treatment. (Illustration 8)

C) For a mini-raised panel cut on the drawers, use the drawer front bit. (Illustration 9)

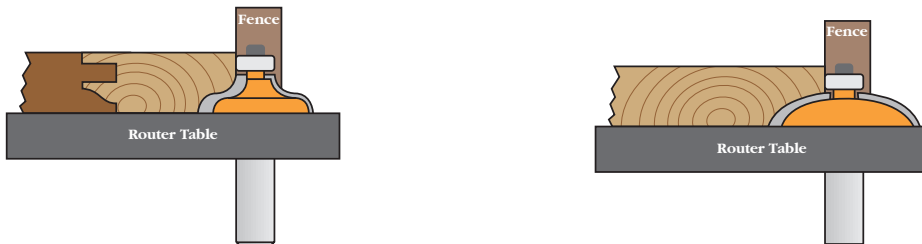

FOR MORE HELP ORDER OUR NEW VIDEO "ARCHED RAISED PANELS MADE EASY" SHOWING EVERYTHING HERE IN MUCH GREATER DETAIL.

© COPYRIGHT 1998 • MARC SOMMERFELD AND CMT UTENSILI SRL

---

# The Easy Mark

— U.S. Patent 5,813,803 —

Mounting door handles and drawer pulls has always been both difficult and time-consuming. The holes had to be located, centered, and drilled accurately so that the handles and pulls would line up perfectly. The new Easy Mark makes alignment simple and fast with absolute accuracy on any size door or drawer.

A ledge along the back of the tool allows it to rest on the top of the drawer front as it is centered with the horizontal scales on each side. A sliding stop on the right side holds the alignment for repeated use on same-size drawer fronts. Three hardened steel bushings located in the sliding triangle are then centered vertically along the tool's half scale and locked into place for drilling. The two outside bushings are adjustable to accommodate 3" - 4-1/2" center handles.



Description	Order No.	List Price \$
The Easy Mark	EZM - 001	<b>79.90</b>

## 899.051.00 COMPLETE INLAY-KIT

Includes 1/8" Solid Carbide Spiral Bit with 1/4" Shank

**\$ 43.90**

LIST PRICE

## 899.052.00 COMPLETE INLAY-KIT

Includes 1/8" Solid Carbide Straight Bit with 1/4" Shank

**\$ 36.90**

LIST PRICE

Making the beautiful effects of professional inlays isn't as difficult as it may seem if you start with the CMT Inlay Kit. Solid brass components come with either a solid carbide spiral bit or straight bit with 1/8" cutting diameter and 1/4" shank. The interchangeable brass bushing and your own template design make it easy - just remove and re-assemble the small bushing to make the recess in the workpiece and cut out the inlay. See instructions included with the kit for complete details. The CMT Inlay Kit gives you unlimited decorative possibilities and is the perfect tool for toymaking, puzzle making and lettering ideas. Spiral bit recommended for use in MDF. Straight bits recommended for natural wood.

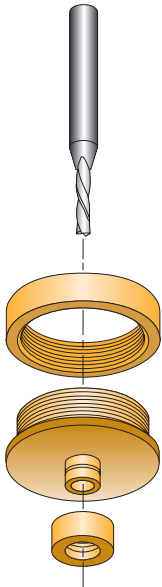
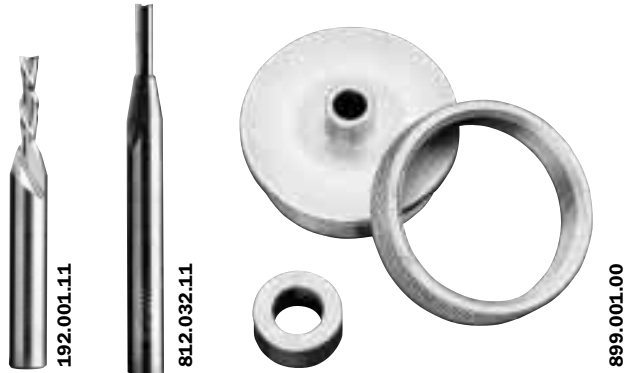

Complete instructions for how to assemble and use the CMT Inlay Kit are included in the kit.

Set Contains	Cutting Diameter	Order No. 1/4" Shank	List Price \$
Solid Brass Template Guide		899.001.00	<b>19.90</b>
Solid Carbide Spiral Bit	1/8"	192.001.11	<b>22.90</b>
Solid Carbide Straight Bit	1/8"	812.032.11	<b>16.90</b>



# Inlay Kit Instructions



**899.051.00** COMPLETE INLAY-KIT Includes 1/8" Spiral Bit with 1/4" Shank

**899.052.00** COMPLETE INLAY-KIT Includes 1/8" Straight Bit with 1/4" Shank

The CMT Inlay Kit consists of 1 template guide, 1 bushing and 1 locking ring.

For best results, use either a 1/8" CMT straight bit item #812.032.11 or CMT spiral router bit item #192.001.11. The Inlay Kit is designed for internal or external pattern routing and requires the operator to make and/or follow a pattern for a perfect match.

## MAKE A PATTERN

Make a pattern of the desired shape out of 1/4" thick material. See **diagram 1**

Masonite or similar material is recommended to provide a smooth surface for the template to run against during the cutting operation. Make the pattern with 3" - 5" of excess material around the perimeter to allow for clamping and to support the router base when designing the pattern. Remember to make the opening large enough to accommodate the 9/16" bushing. Also remember that patterns with a square corner or tight radius will require slight modification of the piece to be inlaid. Instructions for using the internal pattern style are given below. If you choose the external pattern, reverse the procedure for installing and removing the bushing. Cut the external pattern so you preserve the image or design as shown in diagram 2.

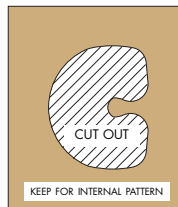

DIAGRAM 1

For internal patterns, cut with a scroll saw. You should end up with a one piece pattern as shown in diagram 1. Preserve the exterior part.

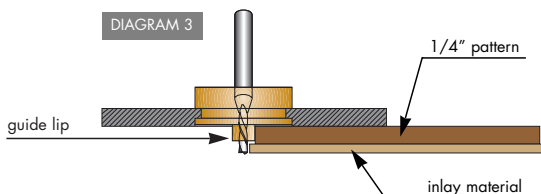
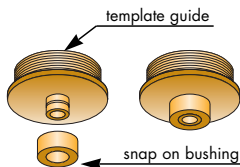

DIAGRAM 2

For external patterns

## INSTALLATION

Attach the two-piece brass inlay guide to your base plate with the locking ring. Ensure that the guide lip extends below the router base, and tighten the locking ring until snug. Set the cutting depth of the router to the equivalent thickness of the inlay material (not to exceed 1/8"). See diagram 3



*NOTE: This inlay template is designed to fit Porter-Cable style base holes and your router may require an additional adapter available from the manufacturer.*

## ROUTING THE WORK

Clamp the Internal pattern to the workpiece and ensure neither will slip. See diagram 4 Place the bushing onto the template guide, previously installed on the router. Carefully lower or plunge the cutter into the workpiece, with the bushing rubbing against the edge of the pattern. Run the router clockwise around the inside of the pattern. This will produce an outline of your pattern and the start of the recess to receive the inlay. See diagram 5 The remaining material must be routed out by moving the router back and forth. Some slight clean-up of any high spots may be done with a chisel.

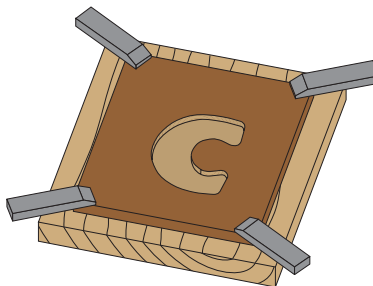

DIAGRAM 4

internal pattern clamped to workpiece

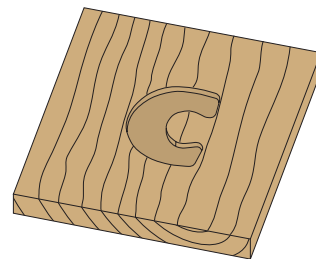

DIAGRAM 5

Routed workpiece: the workpiece has the area routed out 1/8" deep or less and is ready to receive the inlay.

*Note: An external pattern is much more difficult to clamp. Double-sided tape may also be used to secure the patterns to the workpiece.*

## ROUTING THE INLAY

The area from which the inlay will be cut should be secured to a piece of scrap wood using two-sided adhesive tape. This will prevent the inlay from chipping or flying out when the cut is completed.

Place the same pattern over the material from which the inlay will be cut and clamp securely. See diagram 6. Remove the small bushing and carefully route clockwise around the pattern. Ensure that you stay tight to the perimeter of the pattern, as any deviation will show up in the finished work.

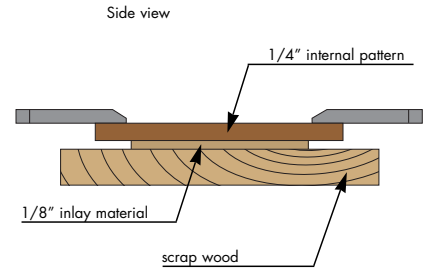
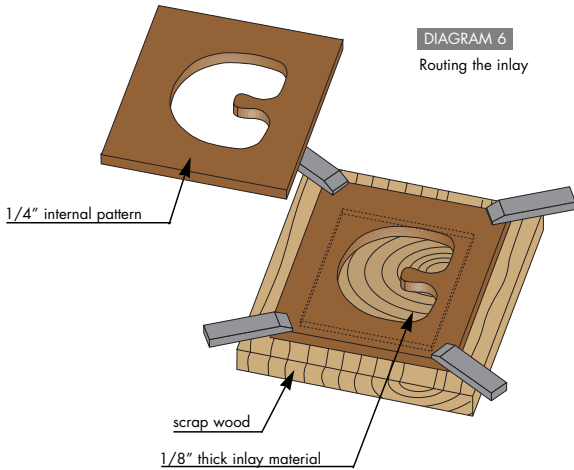

## INSERTING THE INLAY

Check the fit by partially inserting the inlay stock into the workpiece recess. It will likely be necessary to sand the edges and corners of the inlay to provide an exact fit into the recess. You will have a tight fit and care must be taken not to over-sand, which would result in a poor fit. Difficulty in insertion will likely be in a corner or small radius so trim there first.

Do not press the inlay completely into position unless you intend for it to stay.

Once inserted it is very difficult to get out, even without glue.

When ready for final assembly, apply a small amount of the appropriate adhesive to both mates. Take a small scrap of wood and, with a hammer or your hand, gently tap the scrap to drive the inlay into position. See diagram 7

Your desired effect will be evident and if the recess is cut to a depth equal to the thickness of the inlay it will be flush with the surface.

Of course, you may sand either the workpiece or the inlay to achieve that effect. This is also designed to permit the inlay to stand proud of the surface or be slightly recessed.

